

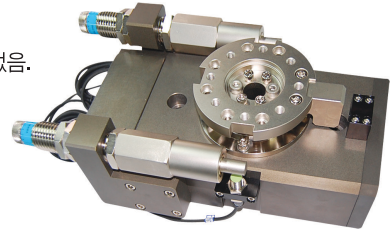

특징 (Character)

- 전체 회전각의 중간 위치에서 정지가 가능한 회전실린더
 - MSRJ□□-180의 경우 90도에서 정지가 가능
 - 고객이 요청하는 임의의 전체회전각도 및 정지각도의 제품도 제작이 가능.
 예) MSRJ30-180(60+120) : 전체회전각은 180도이며, 반시계방향으로 60도 회전위치에서 정지
- 신기술의 특허 등록제품
 - 중간정지시 양쪽 PISTON이 압축공기에 의해 상호 추력을 발생하므로 BACKLASH가 없음.
 - 정, 역회전시 연속적이거나 선택적인 중간정지가 가능.
 - 정, 역회전 중 한방향, 양방향 모두 중간정지를 사용하지 않을수도 있습니다.
 - 중간정지 위치의 미세조절이 가능합니다.
- SDRJ와 동일한 취부규격(길이부분만 차이)으로 사용편의성 확대.
 - SINGLE PISTON 방식으로 회전력은 SDRJ의 약 1/2로 주의바랍니다.
 - 약간의 길이 방향의 여유만 확보되면 SDRJ가 취부되었던 위치에 교체, 부착이 가능합니다.
- 기준위치, 중간정지위치, 완전회전 위치에서 근접센서를 이용한 위치검출이 가능합니다.
 - 전체회전각 = 180도(90+90)의 경우에만 해당하며 기타각도의 제품은 본사와 협의바랍니다.
 - 중간위치 감지센서의 경우 정지하지 않고 통과시에도 감지가 되므로 주의하십시오.
- Rotary cylinder that may stop at the position in the middle of total rotation angle
 - In case of MSRJ□□-180, it enables to stop at 90 degrees.
 - We can supply the product with optional total rotation angle and stop angle required by the customer
 Ex) MSRJ30-180(60+120) : Total rotation angle is 180 degrees which stops at the position where it rotates up to 60 degrees counter-clockwise
- Patent-registered product with new technology
 - When it stops in the middle, both side pistons generate thrust forces mutually by compressed air, resulting in the non-occurrence of backlash.
 - During forward/reverse rotation, it enables repeated or selective intermediate stop.
 - During forward/reverse rotation, it may not use intermediate stop in both unidirectional and bidirectional cases.
 - It enables fine control at the intermediate stop position.
- SDRJ the same mounting dimensions (length, minor differences in delivery) and expanding Usability
 - For SINGLE PISTON torque in a manner SDRJ about 1/2, please note.
 - If you get a little long in the direction SDRJ a mounting location that was replaced, can be mounted.
- Enables position detection using proximity sensor at reference position, intermediate stop position, and complete rotation position.
 - Total rotation angle = Applicable to the case of 180 degrees (90+90) only. For the product with any other angles, please consult with our Head Office.
 - In case of the sensor detecting the intermediate position, be careful as it may detect the position when just passing



주의사항 (Caution)

- 2배의 추력을 가진 정지용 PISTON이 내장되어 중간정지 후 후퇴하여 잔여각을 회전하므로 배압속도가 현저히 낮을 경우 스틱현상이 발생할 수 있습니다.
- 중간정지위치 ↔ 완전회전위치구간은 저속운동 특성이 양호하지 않을 수 있습니다.
- 중간정지시 여유각은 $\pm 3^\circ \sim \pm 5^\circ$ 이하이며 이외의 여유각은 문의바랍니다.
- With a piston for stopping having 2 time thrust force built in, it stops in the middle, reverses, and then rotates by the remaining angle, and therefore a stick phenomenon may occur when the back pressure speed is exceptionally slow.
- In the zone of intermediate stop and complete rotation, the property of low speed motion may not be sound.
- In the case of intermediate stop, the clearance angle $\pm 3^\circ \sim \pm 5^\circ$ or less. For the clearance angle for other cases, consult with our Head Office.

내부구조도 (Exploded view)

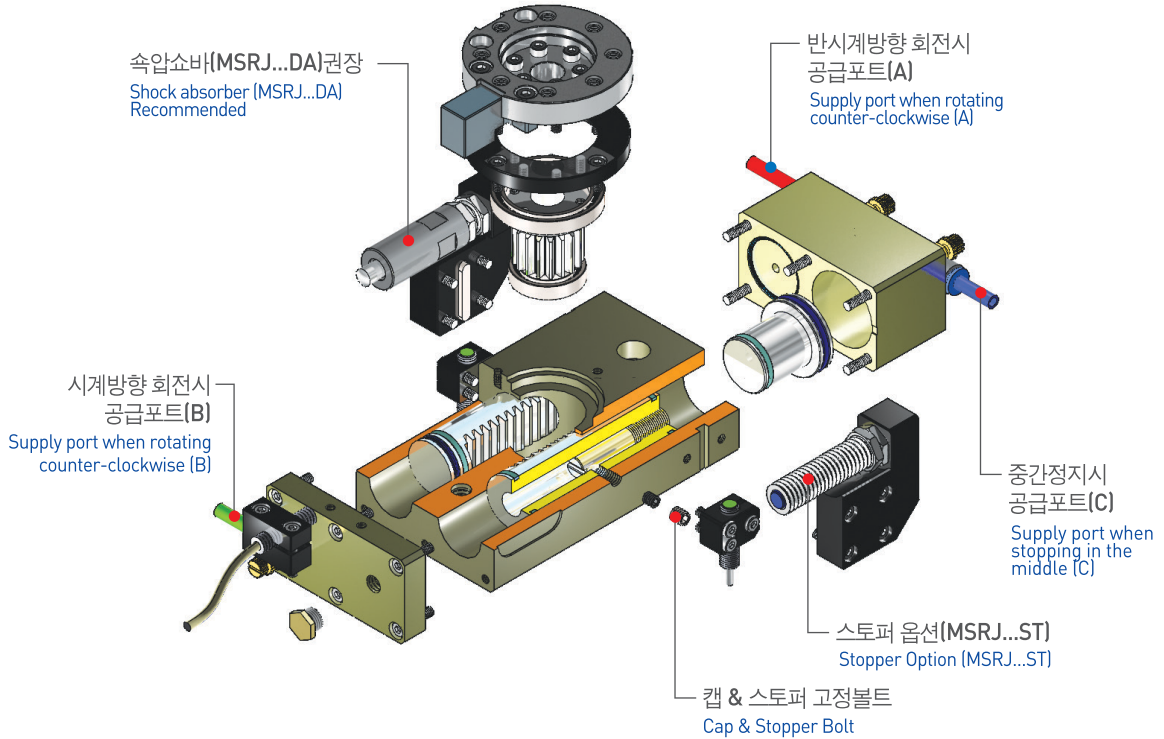

중간정지 위치조정법 (How to adjust the position of intermediate stop)

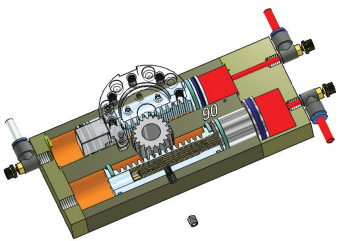
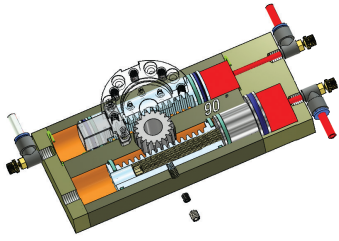
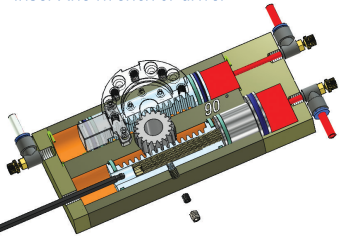
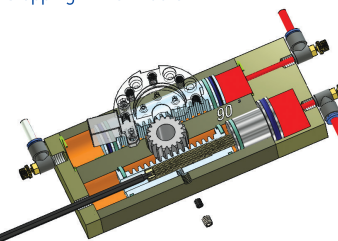
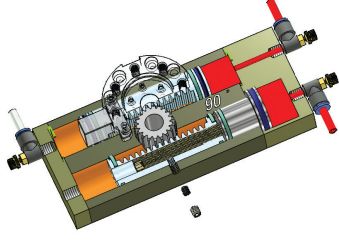
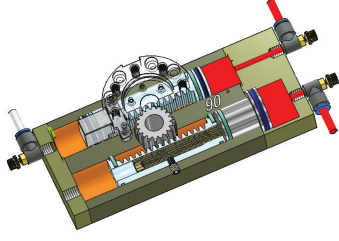
<p>1. BODY 정면의 캡볼트를 분리 Remove the cap bolt in the front</p> 	<p>2. STOPPER 고정볼트를 분리 Remove the fixing bolt</p> 	<p>3. 렌치나 드라이버를 삽입 Insert the wrench or driver</p> 
<p>4. 원하는 중간정지 위치까지 조절 Adjust it to the desired position for stopping in the middle</p> 	<p>5. 고정볼트를 고정 Fasten the fixing bolt</p> 	

주문기호 (Ordering Code)

- SRJ
- SDRJ
- RJC
- RTU
- SSU
- MSRJ

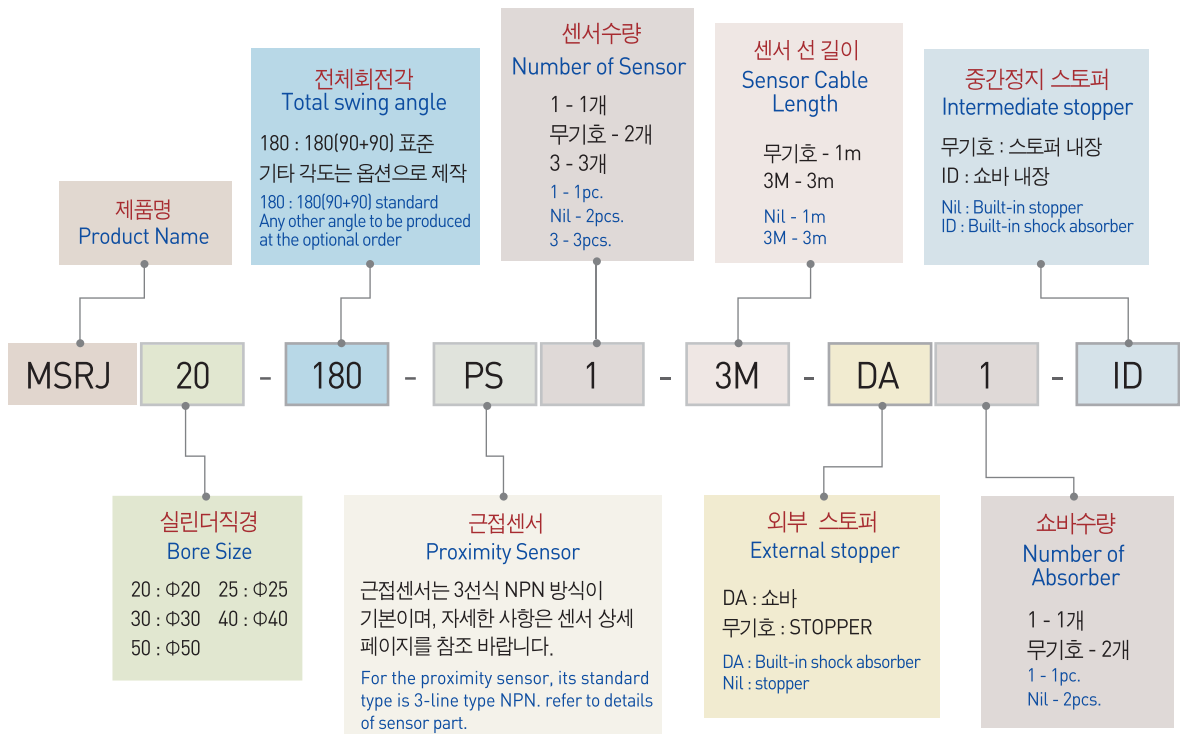

제품사양 (Specification)

P=공기압력(bar)
P=Air Pressure(bar)

제품명칭 Products Name	MSRJ20	MSRJ25	MSRJ30	MSRJ40	MSRJ50	단위 Unit	
실효토크 Actual Torque	0.26xP	0.55xP	0.79xP	1.6xP	3.2xP	N.m	
적재부하 Live loads	9	12	14	16	20	kg	
제품중량 Weight	2.3	2.9	4.2	7.6	13.9	kg	
회전시간 Turning Time	0.6 to 1.0	0.6 to 1.2	0.8 to 1.6	1.0 to 2.0	1.5 to 2.5	sec	
1사이클당 공기소비량 Air consumption quantity	19.2	61.6	88.7	125	252	cm ³ /	
내장속 압쇼바 Built-in shock absorber	M10x1p	M10x1p	M14x1.5p	M20x1.5p	M25x1.5p		
중간정지여유각 Intermediate stop clearance angle	±4	±3	±5	±3	±3	degree	
배관접속구 Fitting size	3-PF 1/8	3-PF 1/8	3-PF 1/8	3-PF 1/8	3-PF 1/8		
반복위치정밀도 Repetition Accuracy						±0.05	degree
사용압력 Operating pressure						3 to 7	bar
주위온도 Ambient temperature						-5 to 60	°C
윤활 Lubrication						불필요 Needless	

1) 적재 부하는 수평상태에서 회전중심에 위치시킨 대상물의 최대하중입니다.
Live load means the max. load of the subject with it placed on the center of rotation under the horizontal status.

반복정밀도 : 연속100회 작동 후 측정치
After 100 consecutive strokes to end positions

MSRJ20

MSRJ20-180-PS3

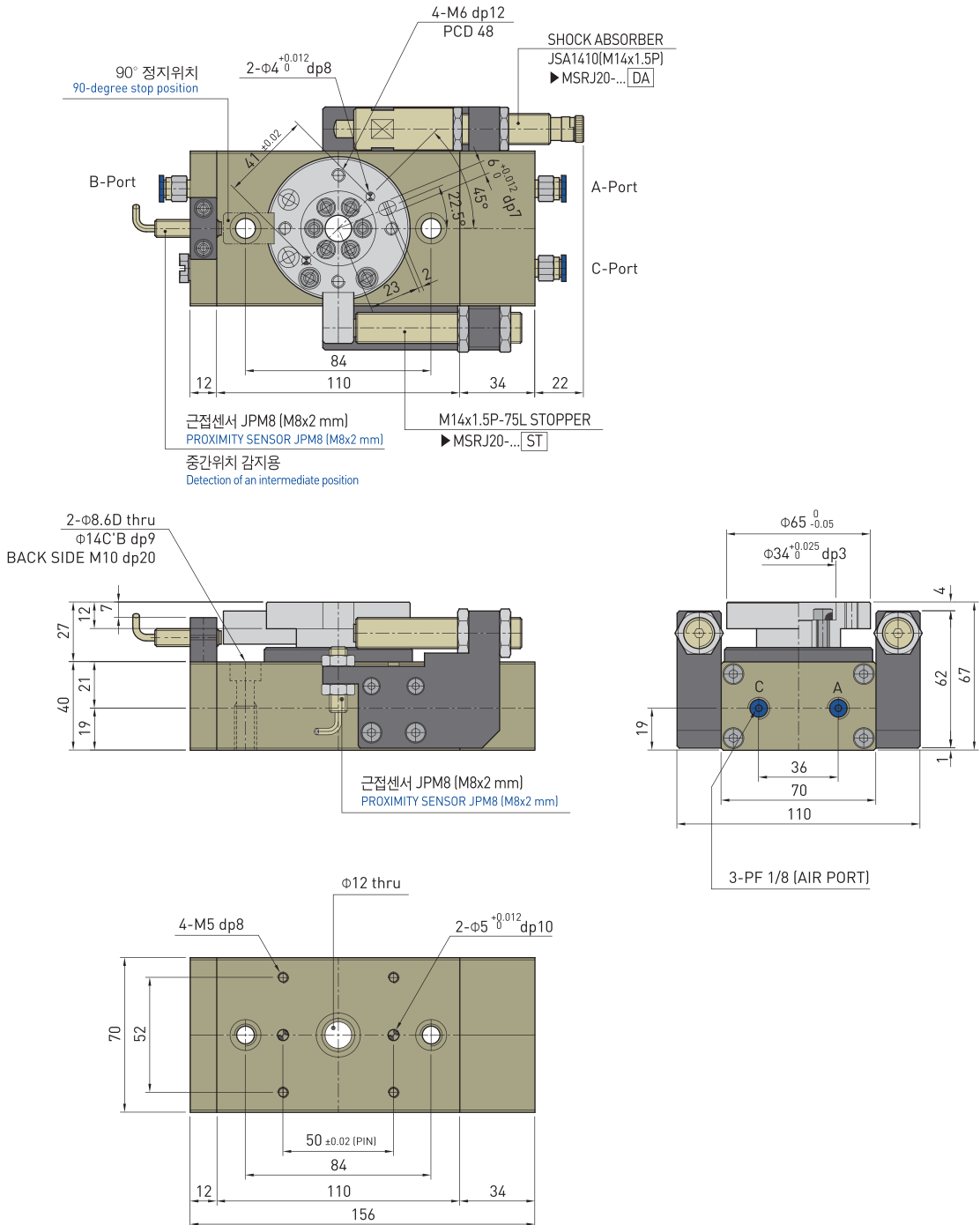

MSRJ25

MSRJ25-180-PS3

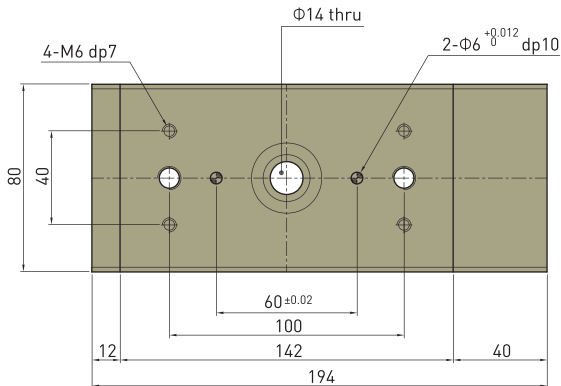
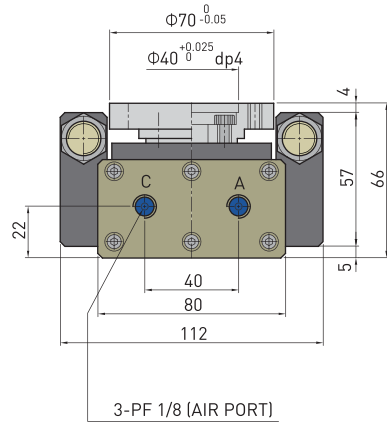
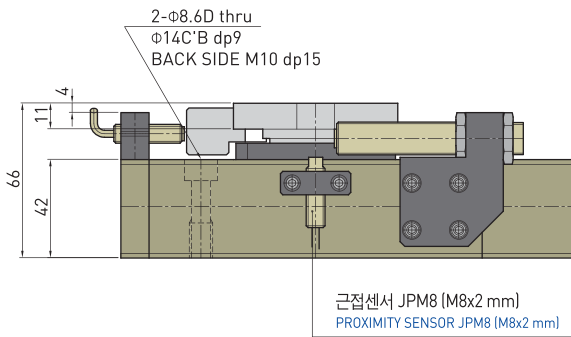
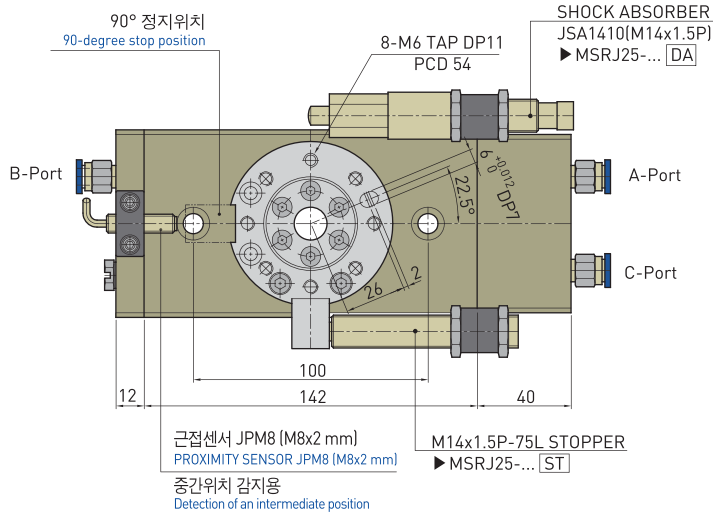

MSRJ30

MSRJ30-180-PS3

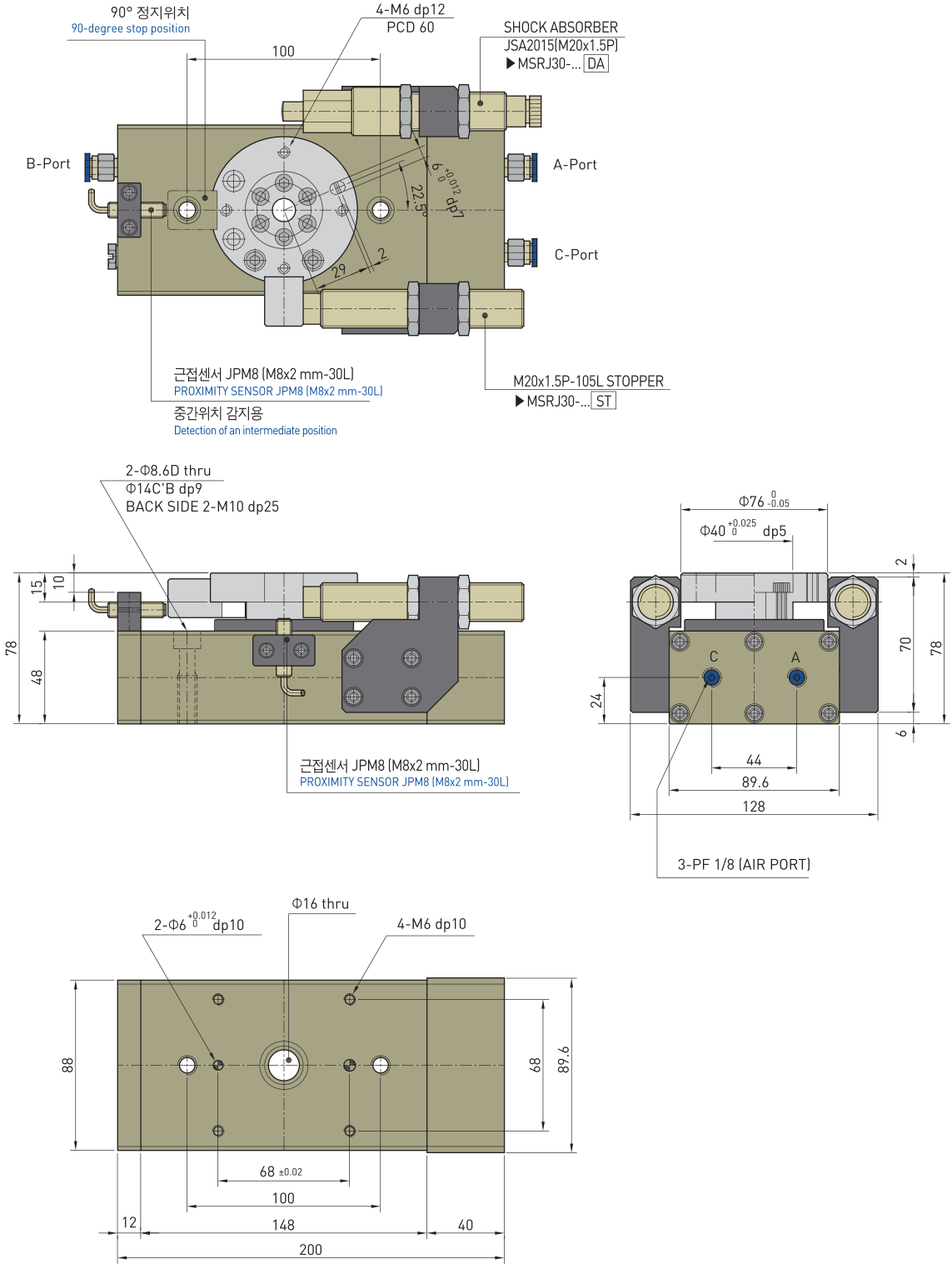

MSRJ40

MSRJ 40-180-PS3

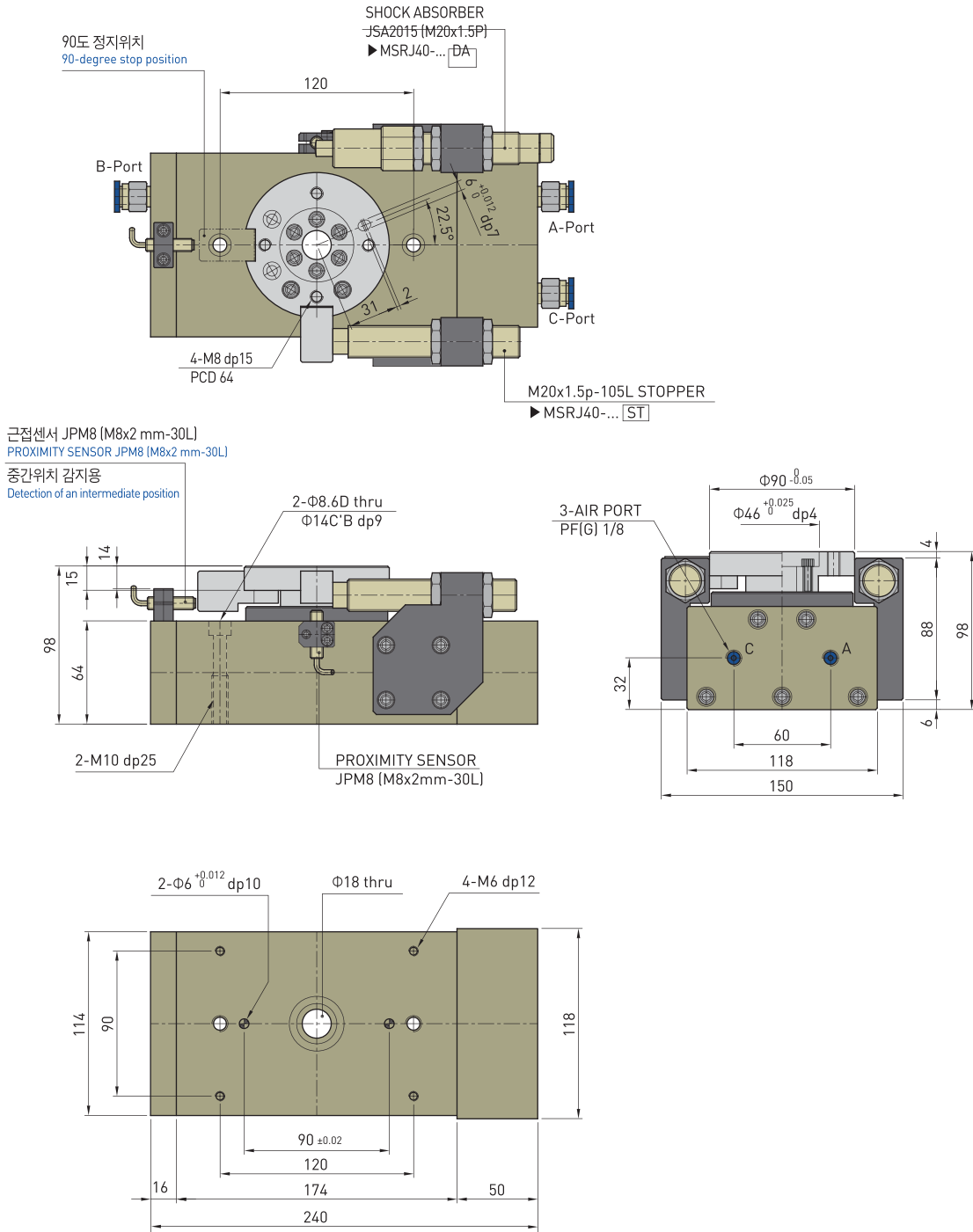

MSRJ50

MSRJ50-180-PS3

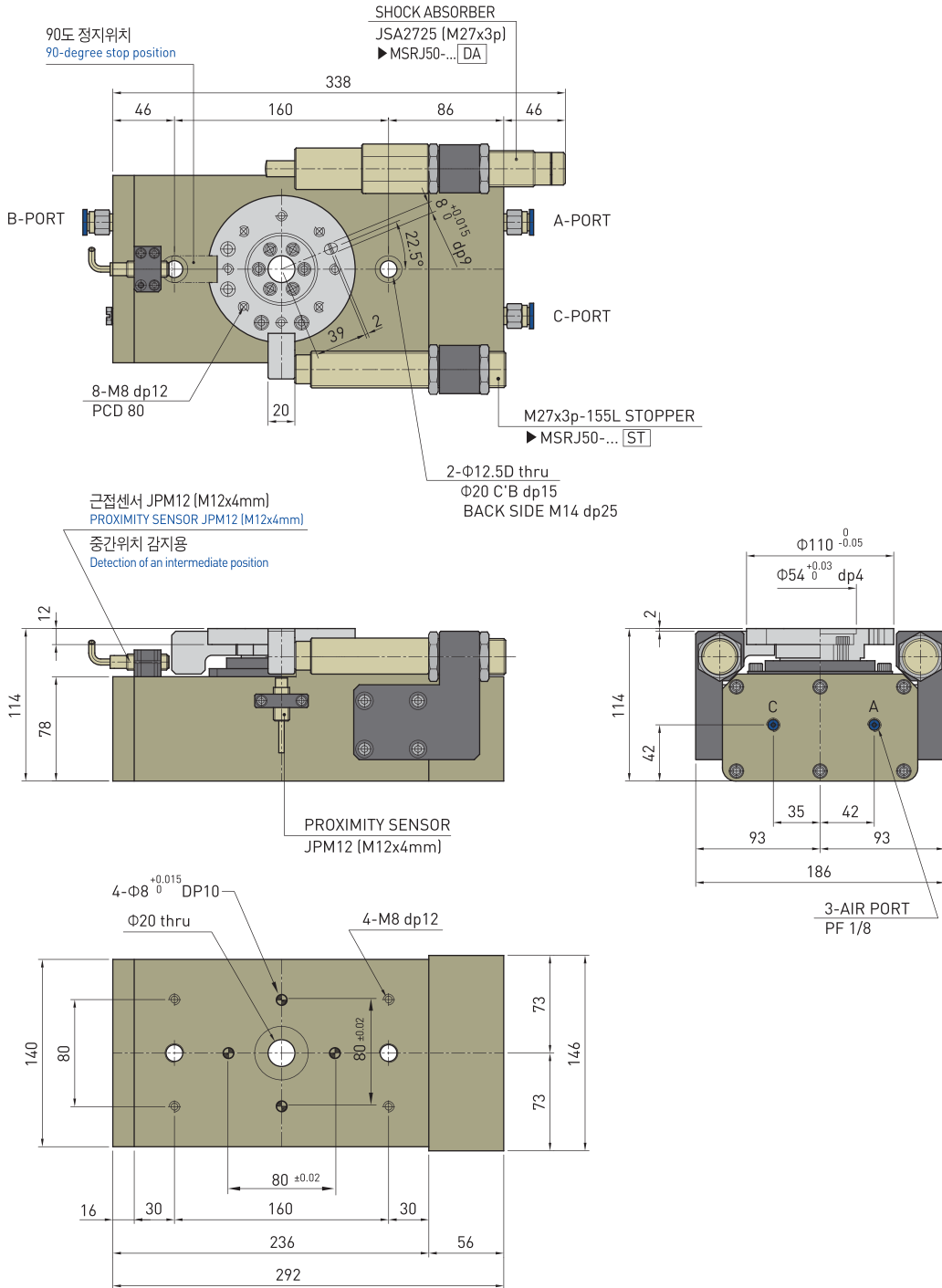

배선도 (Wiring Diagram)

기준(0도)위치
Reference (0 degree)
position

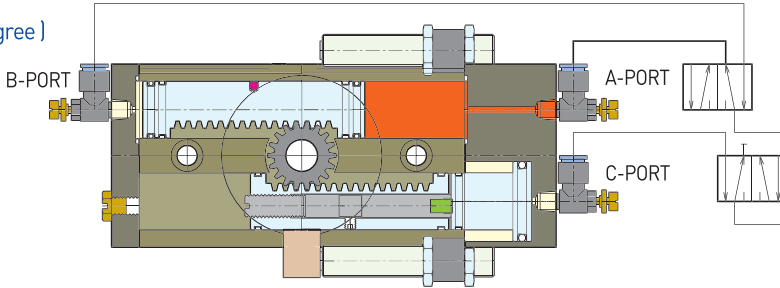

기준(90도)위치
Reference (90 degree)
position

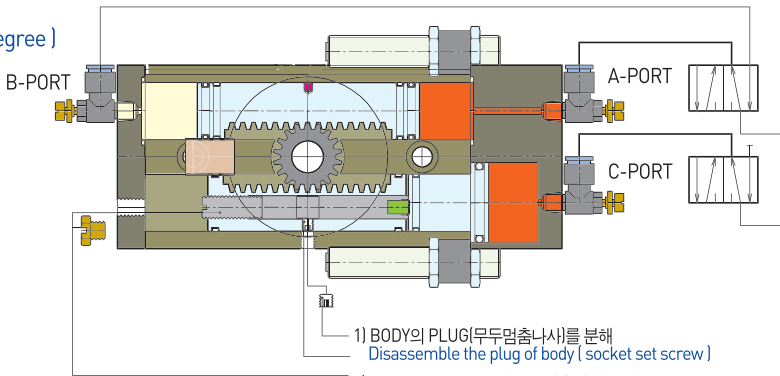

- 1) BODY의 PLUG(무두멈춤나사)를 분해
Disassemble the plug of body (socket set screw)
- 2) STOPPER PISTON의 무두멈춤나사를 이완
Unfasten the socket set screw of stopper piston
- 3) BODY 좌측의 PLUG를 분해후 STOPPER BOLT를 조절
Disassemble the plug at the left side of the body, and then adjust the stopper bolt
- 4) 위의 3단계를 역순으로 실행
Reverse the afore-mentioned three steps

완전회전(180도)위치
Completely rotated
(180 degree) position

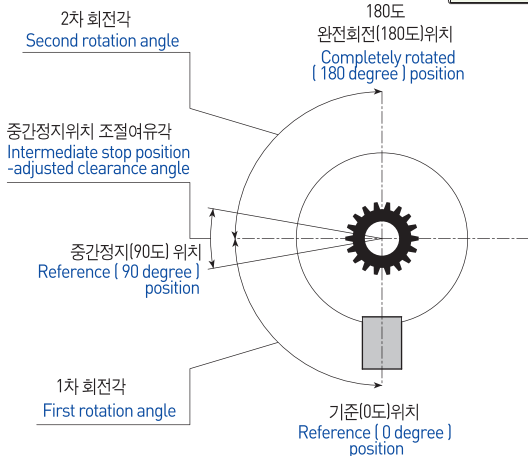
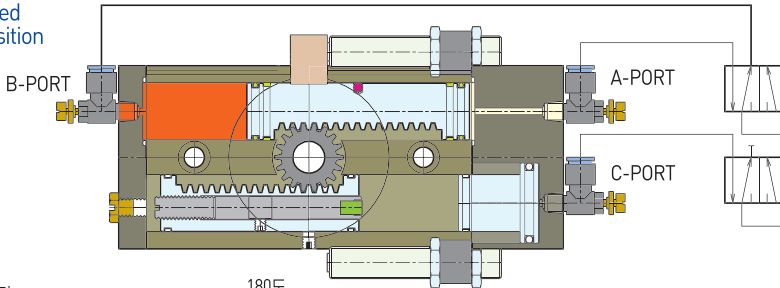

- MSRJ30-180(60+120)
1차 회전각은 60도, 2차회전각은 120도를 가진 MSRJ30-180
MSRJ30-180(60+120)
MSRJ30-180 with 1ST and 2ND rotation angles set to 60 to 120 degrees respectively
- MSRJ20-120(90+30)
1차 회전각은 90도, 2차회전각은 30도를 가진 MSRJ20-120
MSRJ20-120(90+30)
MSRJ30-180 with 1ST and 2ND rotation angles set to 90 to 30 degrees respectively